

## Headrest adjustment:

To rise: Hold the headrest (①) with both hands and lift it up to a suitable height.  
 To lower: Hold the headrest with both hands and pull it down to a suitable height.  
 To adjust the headrest angle: Hold the headrest with both hands and turn it to a suitable angle.

## Back height adjustment:

To rise: Hold the bottom of the chair back (②) with both hands and lift it up to a suitable height step by step.  
 To lower: Hold the bottom of the chair back with both hands and lift it step by step. After crossing the highest position, the back can be lowered to the lowest position.  
 Attention: Backrest can NOT lower down during the adjustment to upward; Only can lower down to lowest position when reaching the highest position and release your hands.

## Armrest adjustment (③):

Armrest height: Pull up the button while holding the armrest and lift it up or lower it down.  
 Armpad forward/backward: Grasp the armpad and slide forward or backward.  
 Armpad angle: Grasp the armpad and pivot to the left or right.  
 Armrest width: Grasp the armpad and press the button under the armpad, move horizontal to the left or right.

## Seat height adjustment (④):

To raise: Lift up the lever when leaving or half up, release the lever when reaching a desired height.  
 To lower: While seated, lift the lever up, release the lever when reaching a desired height.

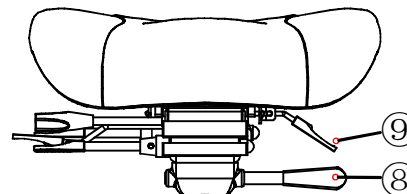
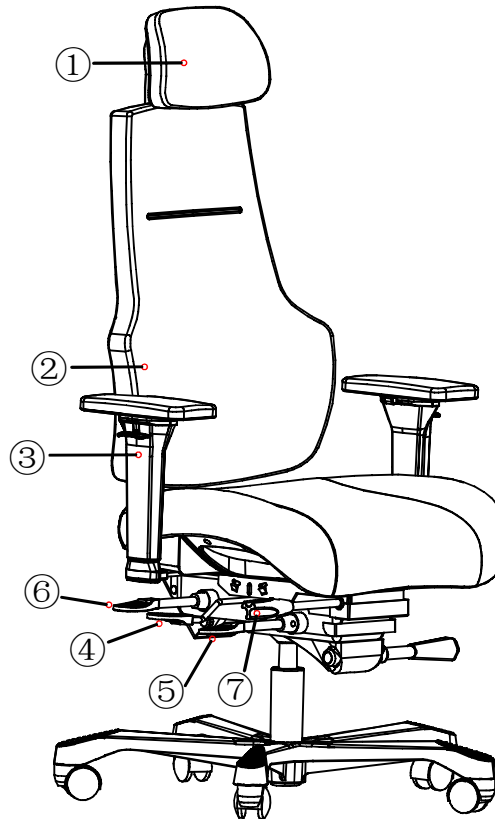

## Tilt angle adjustment (Tilt/Swing Lock) (⑤):

To unlock: Pull up the adjustment lever.  
 To lock: Push down the adjustment lever when reaching a desired angle.

## Independent backrest angle adjustment (⑥):

To unlock: Pull up the adjustment lever.  
 To lock: Push down the adjustment lever when reaching a desired angle.

## Seat angle adjustment (⑦):

To lift up: Turn anticlockwise the seat angle adjustment handle.  
 To lower down: Turn clockwise the seat angle adjustment handle.

Tips: When using this function, please sit on the chair, lie back to keep the chair body at a recline posture, then it is easier to turn the handle.

## Tilt tension adjustment (⑧):

To increase: Turn the knob clockwise/forward to stronger.  
 To reduce: Turn the knob anticlockwise/backward to weaker.

## Seat depth adjustment (⑨):

To increase: While seated and pull up the lever, at the same time, push your hips forward to slide the seat cushion to a proper position, and then release the lever.  
 To reduce: When leaving or half up, pull up the lever, and the seat cushion can return to the rear position, or release the lever when it reaches the desired position.